



LAMILUX Flat Roof Access Hatch Comfort

Solo and Duo - Instruction Manual

CONTENTS

1. General	4 - 7
1.1 Information about the instruction manual	
1.2 Instructions for use	
1.3 Explanation of symbols	
1.4 Warnings	
1.5 Limitations of liability	
1.6 Copyright protection	
1.7 Replacement parts	
1.8 Customer service	
1.9 Manufacturer's address	
2. Safety	8 - 13
2.1 General information	
2.2 Responsibility during installation and operation	
2.3 Personnel requirements	
2.3.1 Personnel qualifications	
2.3.2 Unauthorised persons	
2.3.3 Instruction	
2.4 Intended use	
2.5 Demarcation of the danger zone	
2.6 Special hazards	
2.6.1 Electrical system	
2.6.2 Mechanical system	
2.7 Danger of falling	
2.8 Personal protection equipment	
2.9 Safety devices	
2.10 Signage at the roof access hatch	
3. Technical data	14 - 16
3.1 Data sheet	
3.2 Dimension sheet	
3.3 Type plate	
3.4 Ambient conditions	
4. Transport, installation and connection	16 - 23
4.1 Safety	
4.2 Transport	

4.2.1 Transport inspection	
4.2.2 Packaging/storage	
4.2.3 Transport variants	
4.3 Assembly	
4.3.1 Preparation	
4.3.2 Connection	
5. Description	24 - 25
5.1 Functional description	
5.2 Operating elements	
6. Operation	26 - 30
6.1 Safety	
6.2 Commissioning	
6.3 Operation	
7. Maintenance	31 - 34
7.1 Safety	
7.2 Maintenance	
7.3 Repairs	
7.4 Cleaning	
8. Troubleshooting	35 - 36
8.1 Safety	
8.2 Malfunction and troubleshooting	
9. Disassembly and disposal	37 - 38
9.1 Safety	
9.2 Disassembly	
9.3 Disposal	
10. protocol of the safety inspection	39 - 40
11. Declarations of conformity	41 - 44
12. Notes	45 - 47

1. GENERAL

1.1 Information about the instruction manual

This instruction manual enables the safe and efficient handling of the "LAMILUX Flat Roof Access Hatch Comfort Solo and Duo", hereinafter referred to as 'roof access hatch'.

This instruction manual is part of the roof access hatch and must be kept in the immediate vicinity of the access hatch and accessible to the personnel/operator at all times. The personnel/operator must have thoroughly read and understood this instruction manual before beginning any work.

All safety and handling instructions in these operating instructions must be followed in order to ensure safe work.

The local accident prevention regulations and general safety provisions for the roof access hatch's area of use also apply.

Illustrations in this instruction manual are for basic understanding and may deviate from the actual design of the roof access hatch.

1.2 Instructions for use

The pages of the instruction manual are numbered consecutively.

To help you find a section more quickly, a list of contents is provided behind the cover sheet of the instruction manual.







If the instruction manual contains basic or further information on a topic elsewhere, the user of the instruction manual is referred to this by cross-references.

All illustrations and drawings in this instruction manual are for general illustration purposes and are not necessarily to scale for better presentation of the facts. They may differ slightly from the actual design of the roof access hatch.

1.3 Explanation of symbols

Warnings in this instruction manual are additionally marked with warning symbols.

The following warning symbols are used in this instruction manual:

Symbols	Significance
	General warning
	Risk of electric shock
	Risk of crushing
	Danger from floating loads
	Risk of falling
	Risk of environmental pollution
	Do not enter! Do not climb on!

Symbols	Significance
i	Information text ...

1.4 Warnings

The warnings used in these operating instructions are introduced by signal words which express the level of danger.

The warning symbol also indicates the type of danger.

The following warnings are used in these operating instructions:

Danger	
	<p>Danger to life!</p> <p>Consequences of non-compliance ...</p> <p>>> Instructions on prevention</p>

A warning of this danger level denotes an impending hazardous situation.

If the hazardous situation is not avoided, it will cause death or severe injuries.

Follow the instructions in this warning to avoid the risk of death or severe personal injury.

Warning	
	<p>Risk of injury!</p> <p>Consequences of non-compliance ...</p> <p>>> Instructions on prevention</p>

A warning of this danger level denotes a potential dangerous situation.

If the hazardous situation is not avoided, it will cause death or severe injuries.

Follow the instructions in this warning to avoid the potential risk of death or severe personal injury or severe personal injury.

Caution	
	<p>Personal injury from ...</p> <p>Consequences of non-compliance ...</p> <p>>> Instructions on prevention</p>

A warning of this danger level denotes a potential dangerous situation.

If the hazardous situation is not avoided, it will cause slight to moderate injuries.

Follow the instruction in this warning to avoid the risk of personal injury.

Attention	
	<p>Property damage from ...</p> <p>Consequences of non-compliance ...</p> <p>>> Instructions on prevention</p>

A warning of this danger level denotes potential property damage.

This situation may lead to property damage if not prevented.

Follow the instructions in this warning to prevent property damage.

Note	
i	Information text ...

A note indicates additional information that is important for further work, or facilitates the work step described.

1.5 Limitations of liability

All information and instructions in these operating instructions have been compiled in accordance with current standards and regulations, best available technology and our many years of knowledge and experience.

We reserve the right to make technical changes when refining the roof access hatches addressed in this instruction manual. No claims may be asserted based on specifications, illustrations and descriptions from these operating instructions.

The manufacturer assumes no liability for damages and operational malfunctions due to:

- Failure to follow this instruction manual,
- Improper use,
- Use of untrained or insufficiently trained personnel,
- Use of impermissible operating media,
- Faulty connection,
- Previous work which was not part of the services or delivery,
- Failure to use original replacement parts and accessories,
- Technical changes and conversions not authorised by LAMILUX Heinrich Strunz GmbH,
- Failure to conduct the specified maintenance work,
- Carrying out welding work on the roof access hatch.

LAMILUX Heinrich Strunz GmbH assumes responsibility for any errors or omissions on our part in the scope of the warranty obligations entered into in the contract. Further claims are excluded. Claims to damage compensation, for any legal reason whatsoever, are excluded.

	Note
i	<p>The operator of the LAMILUX Flat Roof Access Hatch Comfort is recommended to conclude a maintenance contract with LAMILUX Heinrich Strunz GmbH.</p> <p>This will ensure that the roof access hatch is regularly maintained by our service personnel and that the required replacement and wear parts will be available without long delivery periods.</p>

1.6 Copyright protection

All documents are protected under the German Copyright Act (Urheberrechtsgesetz).

Transfer and reproduction of documents (including in excerpt) and use of their content are not permitted without our express consent. Infringements are punishable and will result in damage compensation obligations.

We reserve all rights to exercise commercial property rights.

1.7 Replacement parts

	Warning
	<p>Risk of injury!</p> <p>Incorrect or faulty replacement parts can cause damage, malfunctions or total machine failure, and jeopardize safety.</p> <p>>> Only use original replacement parts from the manufacturer.</p>

1.8 Customer service

Should you have any technical questions about the LAMILUX Flat Roof Access Hatch Comfort, please contact the customer service department of LAMILUX Heinrich Strunz GmbH.

Please include the following specifications when doing so:

- Flat Roof access hatch Comfort
- Year of manufacture
- Product no.

The necessary specifications can be found on the type plate of the LAMILUX Flat Roof Access Hatch Comfort.

1.9 Manufacturer's address

LAMILUX Heinrich Strunz GmbH
Zehstrasse 2
95111 Rehau, Germany

Postfach 1540

Tel.: +49 (0) 9283 / 595 -0

Fax: +49 (0) 9283 / 595 -290

Email: information@lamilux.de

www.lamilux.de

2. SAFETY

2.1 General information

This chapter provides important information on all safety aspects for optimal protection from hazards during installation as well as on safe and trouble-free operation.

Warning	
	<p>Failure to follow the safety instructions poses a hazard!</p> <p>Failure to follow the safety and handling instructions provided in these operating instructions can lead to significant hazards. Be absolutely certain to follow the warnings and instructions provided here.</p>

2.2 Responsibility during installation and operation

The construction company is subject to statutory work safety requirements when installing the roof access hatch.

In addition to the work safety instructions in this instruction manual, the safety, accident prevention and environmental protection regulations applicable to the installation and operation of the LAMILUX Flat Roof Access Hatch Comfort must be adhered to.

Note the following points:

- Provide information on the applicable work safety regulations and conduct a risk assessment to identify additional risks at hand due to the specific work conditions at the roof access hatch's installation site. These must be implemented in the form of operating procedures for the installation and operation of the roof access hatch.
- Secure any hazard points which arise from the installation of the roof access hatch (such as edges which can be fallen from).
- Check whether the operating procedures created match the current state of regulations and update them as necessary over the entire time of the roof access hatch's installation and operation.
- Clearly arrange and determine the personnel's responsibility for installation, operation, maintenance and cleaning.
- Ensure that everyone who handles the roof access hatch has read and understood the instruction manual. Furthermore, personnel must be trained and informed of hazards at regular intervals.
- Ensure that personnel handles the roof access hatch in a safety and risk-conscious manner in observances of the instruction manual.
- Make sure that the instruction manual and all other documents are available to personnel at all times.
- Provide personnel with the necessary protective equipment.

Furthermore, the operator is responsible for en-

sure that the roof access hatch remains in flawless condition at all times.

For this reason, the operator must ...

- ensure that the cleaning and maintenance intervals defined in these operating instructions are complied with.
- check all safety devices on a regular basis to ensure they are functional and complete.

2.3 Personnel requirements

2.3.1 Personnel qualifications

Warning	
	<p>Risk of injury if insufficiently qualified!</p> <p>Improper handling can lead to serious personal injuries and property damage.</p> <p>Only allow all tasks to be carried out by persons who are qualified to undertake such tasks.</p>

These operating instructions specify the following qualifications for various fields of activities:

- Instructed person
has been informed of the work to be carried out and of the potential hazards of improper conduct in a briefing by the operator.
- Qualified personnel
capable of performing the tasks assigned them and identifying and avoiding potential hazards independently thanks to their professional training, knowledge and experience, and knowledge of the relevant regulations.
- Qualified electrician
capable of performing work on electrical systems and identifying and avoiding potential hazards independently to his/her professional training, knowledge and experience, and knowledge of the relevant standards and regulations.

Qualified electricians are responsible for the specific location they are working at and trained for, and are familiar with the relevant local standards and regulations.

Only persons who can be expected to perform their work dependably are authorized as personnel. Persons whose reactions are affected by influences such as drugs, alcohol or medications are not authorised.

Personnel to be trained, taught, instructed or those placed in an apprenticeship may only be assigned installation and operation tasks whilst under the constant supervision of an experienced person!

Note	
	<p>The applicable age and occupation-specific regulations at the installation and operation site must be observed when selecting personnel.</p>

2.3.2 Unauthorised persons

Warning	
	<p>Unauthorised personnel pose a danger to themselves and others!</p> <p>Unauthorized persons who do not meet the requirements described are not familiar with the hazards in the work area.</p> <p>>> Keep unauthorised persons away from the work area.</p> <p>>> If in doubt, approach the persons in question and escort them away from the work area.</p> <p>>> Stop work as long as unauthorised persons remain in the work area.</p>

2.3.3 Instruction

Installation personnel and operators must be briefed by the applicable responsible parties (construction supervisors, operators, etc.) on a regular basis.

Note	
i	Keep a log of the briefings and record the participants by taking their signatures so that the performance of briefings can be better tracked.

2.4 Intended use

The LAMILUX Flat Roof Access Hatch Comfort Solo and Duo is to be used as a roof access hatch on flat roofs. It can also be used for daily ventilation.

Opening and closing always takes place via a control unit with an enabling function, which must be positioned within sight of the element. For this purpose, only the supplied control unit in combination with a key switch without self-stop is to be used as operating element. In addition, the roof access hatch must be the only means of access to the associated roof area (this ensures that no persons enter the danger area from outside unnoticed by the operator during operation).

Any use other than or beyond this is considered to be improper.

Warning	
	<p>Danger due to improper use</p> <p>Any use beyond that of intended use and/or other use of the LAMILUX Flat Roof Access Hatch Comfort Solo and Duo may lead to hazardous situations.</p> <p>>> Only use the LAMILUX Flat Roof Access Hatch Comfort Solo and Duo as intended.</p> <p>Comply with all specifications in this instruction manual.</p>

Any claims due to damages resulting from improper use are excluded.

The operator assumes sole responsibility for any risks.

2.5 Demarcation of the danger zone

The danger zone of the roof access hatch is composed of the following areas with an additional safety distance of 500 mm to each side:

G1: Area vertically below the ceiling opening

G2: Main and secondary closing edges of the cover

G3: Roof area that is below the travel range of the flap (closed to maximum opening range)

In order to limit the risk of falling, a railing must be fitted around the roof access hatch by the customer. In the case of the Solo roof access hatch, this railing is fitted on the opposite side of the flap and opposite the staircase. With the Duo roof access hatch, this is fitted all the way round, except on the exit side.

2.6 Special hazards

2.6.1 Electrical system

Danger	
	<p>Risk of electric shock!</p> <p>Contact with lines or components under power pose a life-threatening danger!</p> <p>>> Work on electrical equipment may only be conducted by a qualified electrician or instructed persons under the guidance and supervision of a qualified electrician in accordance with the rules of electrical engineering.</p> <p>>> Any faults detected in electrical systems/component assemblies/equipment must be rectified without delay. If there is an acute danger, then the system/component assembly/equipment in defective condition cannot be used.</p> <p>>> Parts on which inspection, maintenance and repair work are to be conducted must – if required – be disconnected from the power supply and be secured against being switched on again. The disconnected parts must first be checked to make sure they are not under power, then ground and short them and isolate any neighbouring parts under power!</p>

Danger	
	<p>>> If it is necessary to conduct work on live parts, then a second person must be called in to pull the emergency power shut-off in case of emergency. Block off the work area with a red and white safety change and a warning sign. Only use electrically insulated tools!</p> <p>>> Do not repair or bypass any fuses. Only use original fuses with the specified amperage!</p>

2.6.2 Mechanical system

Warning	
	<p>Risk of crushing!</p> <p>Opening and closing the roof access hatch poses a risk of injury.</p> <p>>> Do not loiter in the danger zone when opening and closing the device</p> <p>>> Do not reach into moving parts.</p> <p>>> Do not disable the sensor</p>



2.7 Danger of falling

Warning	
	<p>Risk of falling!</p> <p>The roof access hatch and roof edges pose a risk of severe to fatal injury from falls.</p> <p>>> Do not step onto edges which could be fallen from.</p> <p>>> Seal off danger zones</p> <p>>> Wear personal protective equipment</p>

2.8 Personal protection equipment

Warning	
	<p>Risk of injury from improper protective equipment or lack of protective equipment!</p> <p>Personal protective equipment must be worn during work to minimize the risk of health risks or personal injury.</p> <p>>> The protective equipment necessary for the task at hand must be worn at all times during work.</p> <p>>> Follow notices on personal protective equipment posted in the work area.</p>

The following protective equipment must be worn during all work on the roof access hatch:

	<p>Protective helmet to protect the head from falling objects or hitting one's head</p>
	<p>Steel-toed safety boots</p>

Special protective equipment is additionally required when performing specific tasks. These are specified separately in the individual chapters. The following protective equipment must additionally be worn during specific work on the roof access hatch:

	<p>Work gloves to protect from injuries</p>
	<p>Harness for fall protection</p>

2.9 Safety devices

Warning	
	<p>Danger due to missing/ non-functioning safety devices!</p> <p>Missing or non-functioning safety devices can cause serious injuries.</p> <p>>> Only operate the roof access hatch if all safety devices are installed and functional.</p>

The LAMILUX Flat Roof Access Hatch Comfort Solo and Duo has been manufactured in accordance with the legal regulations in force in the European Union.

The provisions of standard DIN EN 12978 "Industrial, commercial and garage doors and gates - Safety devices for power-operated doors and gates" have been complied with.

Nevertheless, the roof access hatch can be dangerous if it is operated improperly or not in the proper condition.

Dangers that cannot be ruled out by design are indicated by warning signs on the roof access hatch and safety instructions in the instruction manual.

2.10 Signage at the roof access hatch

Note	
	<p>Warning/danger signs are attached to the roof access hatch to protect the assembly and operating personnel.</p> <p>Observe these signs. Renew damaged or illegible warning/danger signs immediately.</p>



Solo roof access hatch

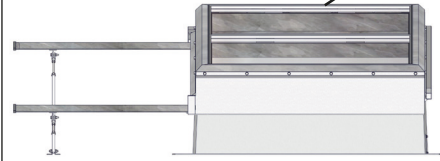

Duo roof access hatch

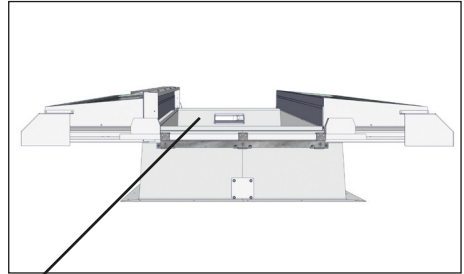
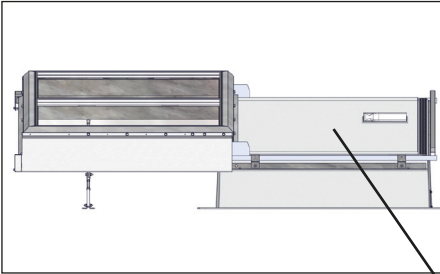
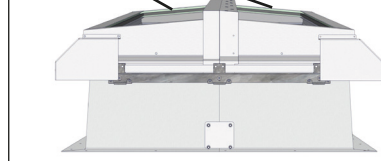

3. TECHNICAL DATA

3.1 Data sheet

Type	LAMILUX Flat Roof Access Hatch Comfort Solo	
Length top roof edge	3500	mm
Width top roof edge	1200	mm
Length	3970	mm
Width	2700	mm
Height	850	mm
Weight	approx. 370	kg
Electrical system		
Connected load	0.25	kW
Power input	1.0	A
line or supply voltage (BE)\ power supply (AE)	230	V _{AC}
Mains frequency	50	Hz
Control voltage	24	V _{DC}
Type	LAMILUX Flat Roof Access Hatch Comfort Duo	
Length top roof edge	3000	mm
Width top roof edge	1200	mm
Length	3310	mm
Width	2360	mm
Height	750	mm
Stroke (both sides)	500	mm
Weight	approx. 280	kg
Electrical system		
Connected load	0.25	kW
Power input	1.0	A
line or supply voltage (BE)\ power supply (AE)	230	V _{AC}
Mains frequency	50	Hz
Control voltage	24	V _{DC}

3.2 Dimension sheet

Solo roof access hatch

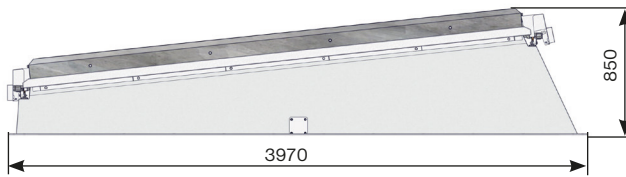
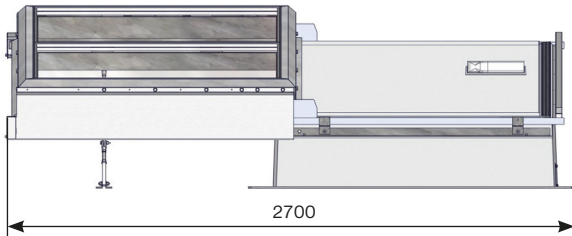

Duo roof access hatch

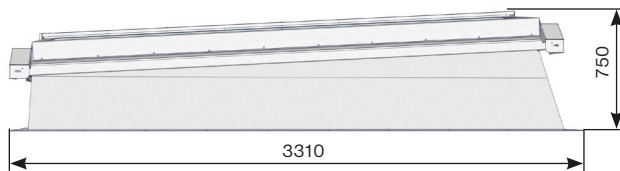
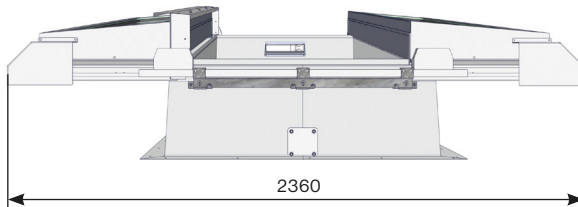

4. TRANSPORT, INSTALLATION AND CONNECTION

3.3 Type plate

The type plate is located on the frame profile (inside).

The type plate has the following information:

- Manufacturer
- Type
- Year of manufacture
- Electrical connected loads of the drives

3.4 Ambient conditions

Temperature range	-30 to +70	°C
Wind load	1500	N/m ²
Snow load	750	N/m ²

4.1 Safety

Warning	
	<p>Risk of injury!</p> <p>Lifting loads poses the risk of severe to fatal injury from falling or uncontrollably swinging parts.</p> <p>>> Never step under suspended loads.</p> <p>>> Observe specifications on the necessary anchor points.</p> <p>>> Do not anchor on protruding parts of the roof access hatch. Make sure that the slings are fastened securely.</p> <p>>> Only use approved lifting gear and slings with sufficient carrying capacity.</p> <p>>> Do not use damaged ropes and/or slings.</p> <p>>> Do not place ropes and belts on sharp edges and corners, and do not tie them into knots or twist them.</p>

Warning	
	<p>Risk of falling!</p> <p>There is a considerable risk of injury at the roof access hatch and at the roof edges</p>

Warning	
	<p>culminating in death due to falling.</p> <p>>> Do not step onto edges which could be fallen from.</p> <p>>> Seal off danger zones</p> <p>>> Wear personal protective equipment</p>

Warning	
	<p>Risk of injury from improper protective equipment or lack of protective equipment!</p> <p>Personal protective equipment must be worn during work to minimize the risk of health risks or personal injury.</p> <p>>> The protective equipment necessary for the task at hand must be worn at all times during work.</p> <p>>> Follow notices on personal protective equipment posted in the work area.</p>

Warning	
	<p>Risk of injury if insufficiently qualified!</p> <p>During assembly and maintenance, there is a risk of injury to the person carrying out the work by working in the danger zone. Incorrect assembly or servicing can cause hazards for subsequent operation.</p> <p>>> Installation and servicing work may only be carried out by qualified personnel.</p>

4.2 Transport

Attention	
	<p>Improper transport can cause damage!</p> <p>Improper transport can cause property damage resulting in great expenses.</p> <p>>> Proceed with caution when unloading packages upon delivery and during in-house transport and observe the symbols and instructions on the packaging.</p> <p>>> Only remove packages shortly before installation.</p> <p>>> Never place the roof access hatch directly on the ground! Place square timbers under the product in order to prevent electrical lines from being shorn off.</p> <p>>> Do not expose the uninstalled roof access hatch to the effects of weathering (moisture).</p>

4.2.1 Transport inspection

Check the delivery for transport damage and make sure it is complete immediately upon delivery.

Note	
	<p>Failure to follow the following instructions may relieve the insurer from its obligation to provide coverage in the event of damage.</p>

Proceed as follows if externally visible transport damage:

- If damage is suspected, only conditionally acknowledge receipt of the delivery (e.g. on the shipping document) and specify the suspected damage.
- With goods in containers, make sure that the containers and locks or seals have been inspected by responsible parties from the shipping company or freight carrier. If a container is damaged, locks or seals have been broken or are missing or differ from the shipping documents, only receive the delivery conditionally and certify it specifying the suspected damage and keep the damaged or improper locks and seals.
- Ensure compensation claims against third parties.

The shipping company, other transporter, forwarding agency, customs and harbour authorities must be

- requested to inspect the damage collectively,
- requested to certify the damage,
- made liable in written form and the damage must be described in detail.

If there is externally visible damage, this must be done before the goods are accepted. If the damage is not externally visible, this must be done immediately after the damage is detected.

- Determine the claim periods and comply with them.

- Make sure to minimise damage which has already occurred and prevent further damage.
- Immediately consult the insurance adjuster specified in the insurance documents, who will determine the damage and provide advice on securing compensation claims against third parties and on damage control measures.
- Do not alter the condition of the shipment and packaging until the insurance adjuster arrives, unless it is necessary to do so to reduce and prevent further damage.
- Immediately notify the insurer of the insurance case and provide it with complete damage documentation to expedite claims processing without delay (at the latest, in good time before any term of exclusion and/or statute of limitations for compensation claims against third parties).

4.2.2 Packaging/storage

The roof access hatch is pre-assembled at the factory to the greatest degree possible and packaged accordingly.

- Leave the roof access hatch in its packaging until installation.
- Cover the roof access hatch and store it at a dry place.

4.2.3 Transport variants

For safe transport, the roof access hatch must remain on the roof until installation, and must remain and be transported in its unopened transport crate. The flat roof window may be transported with a forklift or crane.

	Note
i	A complaint must be filed for any fault as soon as it is discovered. Damage compensation claims can only be asserted within the applicable claim period.

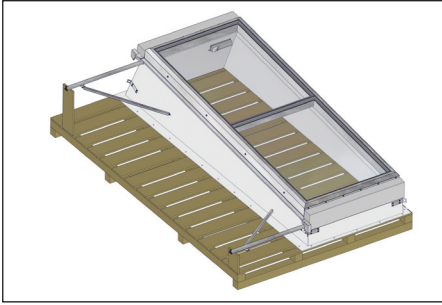

4.3 Assembly

Note: The installation is described in detail in the separate installation instructions.

Only the fastening material listed in the installation instructions is permitted for installation. Installation, connection and commissioning may only be carried out by qualified personnel. After the assembly of the access hatch, the initial commissioning must be carried out by a competent person by means of the safety inspection. The roof access hatch may only be installed with the safety distances specified in DIN EN 349. This means that the following safety distances must be maintained at the maximum projection (corresponding to the open roof access hatch):

- Minimum distance to fixed parts on the roof: 300mm
- In the case of a torso hazard: 500mm

Depending on the upstand and the design on the roof, a corresponding step is to be implemented.

Warning	
	<p>Risk of falling!</p> <p>The roof access hatch and roof edges pose a risk of severe to fatal injury from falls.</p> <p>>> Do not step onto edges which could be fallen from.</p> <p>>> Seal off danger zones</p> <p>>> Wear personal protective equipment</p>

If normal ambient light does not sufficiently illuminate the danger zone, additional lighting must be provided by the customer.

4.3.1 Preparation

Before beginning work, a risk analysis must be conducted to systematically determine how to ensure compliance with state work safety regulations and trade unions' accident prevention regulations.

During the risk assessment, it must also be determined which risks could arise from the function of the roof access hatch in connection with the installation location and which technical or organisational measures must be taken, if necessary. Special attention should be paid to the fact that the roof access hatch has a stroke of 500 mm parallel to the longitudinal axis on both sides. There is a risk of shearing and crushing.

Roof opening

For work preparation:

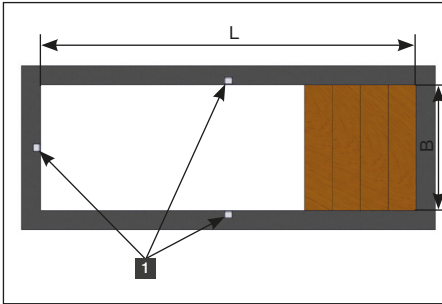

Solo roof access hatch:

L = 3500 mm

W = 1200 mm

1 = Cut-outs for connection cable or terminal box

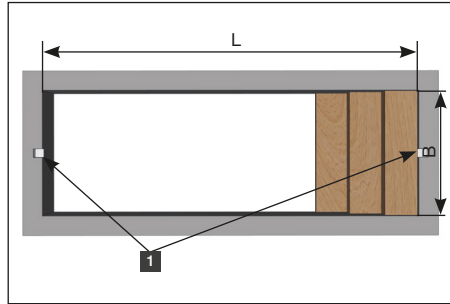

Duo roof access hatch:

L = 3000 - 3070 mm

B = 1200 - 1270 mm

1 = Cut-outs for connection cable or terminal box

Create the roof opening according to the specifications (see sketch above).

Transport and storage at the installation site

Bring the roof access hatch onto the roof using suitable aids (lifting gear, etc.) (see chapter "Transport").

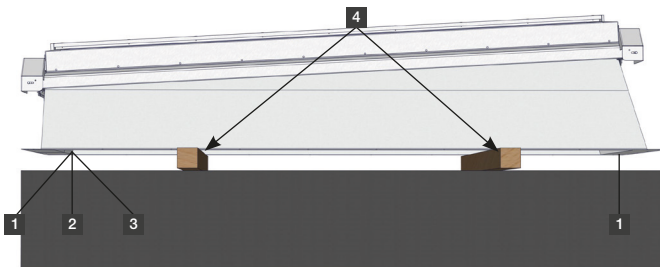

1 = Cable of the electric drives (5x0.75 mm²; approx. 3.6 m)

2 = Sensor cable (7x0.75 mm²; approx. 4.2 m)

3 = Cable of the reed contacts (2x2x0.8 mm²; approx. 3.4 m)

4 = Squared timber as support (cable protection >> against shearing of cables)

	Attention
	<p>Improper storage at the installation site can cause damage!</p> <p>Improper storage at the installation site can cause property damage resulting in great expenses.</p> <p>>> Proceed with caution when unloading packages upon delivery and during in-house transport and observe the symbols and instructions on the packaging.</p> <p>>> Only remove packages shortly before installation.</p> <p>>> Never place the roof access hatch directly on the ground! Place square timbers under the product in order to prevent electrical lines from being shorn off.</p> <p>>> Do not expose the uninstalled roof access hatch to the effects of weathering (moisture).</p> <p>>> Store the roof access hatch well ventilated and avoid heat accumulation.</p> <p>>> Do not lift the roof access hatch with glass suction cups.</p>

4.3.2 Connection

Danger	
	<p>Risk of electric shock!</p> <p>Contact with lines or components under power pose a life-threatening danger!</p> <p>>> Work on electrical equipment may only be conducted by a qualified electrician or instructed persons under the guidance and supervision of a qualified electrician in accordance with the rules of electrical engineering.</p> <p>>> Before starting work, the safety rules of electrical engineering must be followed and applied.</p>

Warning	
	<p>Risk of injury due to improper installation!</p> <p>Only carry out connection work on the control unit supplied in accordance with the enclosed terminal diagram. Modifications to the circuit and control system can lead to serious personal injury or property damage.</p> <p>>> The roof access hatches must under no circumstances carry out automatic travel movements due to the type of actuation or an additional control unit.</p> <p>>> The roof access hatches may only be connected and operated with the sensor integrated in the control unit.</p> <p>>> Never connect drives directly to the supply voltage without a control unit.</p> <p>>> Push-buttons without self-stop are permitted as operating devices for the control unit without exception. Switches or any controls that lead to automated operation (e.g. thermostats, wind/rain sensor controls) are not permitted.</p> <p>>> Fit the operating device within sight of the roofaccess hatch.</p>

	Note
i	To ensure authorised operation of the roof access hatch, we recommend the use of a key switch.

Cable connections on the roof access hatch

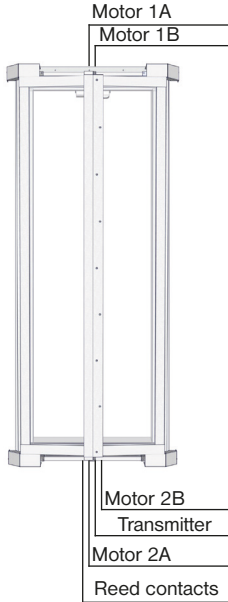

- Mount the terminal box for drives and sensor on the roof connection of the upstand.

	Attention
	<p>Malfunctions</p> <p>Changing the connection cables to the drives (motors) can lead to malfunctions or even total failure of the roof access hatch.</p> <p>>> Bring together the connecting cables of the drives belonging to a drive pair in a terminal box provided by the customer without changing the supply cables (shorten/extend).</p>

- Connect the roof access hatch according to the terminal diagram.

	Note
i	The power supply of the roof access hatch must be a separate circuit.

5. DESCRIPTION

5.1 Functional description

The roof access hatch is designed as a system with one or two opening flaps designed as glass elements. The flaps are each driven by two synchronously operating electric motors.

The opening flaps are moved to the side in a linear movement. Control is via the control unit supplied. The travel movement is triggered by a push-button mounted on site without self-stop, which must be actuated by the operator within sight of the roof access hatch. In addition, the roof access hatch is monitored by a sensor installed in the roof access hatch to prevent danger to persons climbing through.

5.2 Operating elements

Solo roof access hatch

The two electric motor drives are each mounted on the upper and lower side of the flap. The drives open or close the roof access hatch. The drives are connected to each other by a control line and synchronised by internal electronics. A separate synchronous control is not necessary.

Duo roof access hatch

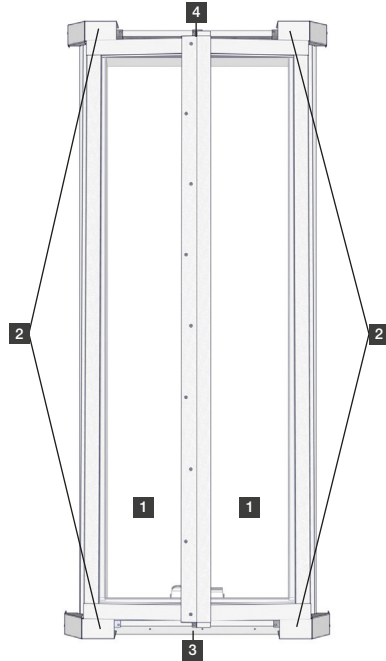

Roof access hatch top view

The four electric motor drives (2) are each arranged in a pair on one of the two opening flaps (1). The drives open or close the roof access hatch. The drives belonging to a pair are connected to each other by two control lines and synchronised by internal electronics. A separate synchronous control is not necessary.

Sensor

The two components of the sensor are factory-mounted centrally on the short sides of the roof access hatch. Receiver (3) and transmitter (4) of the sensor are mounted in alignment with each other. The sensor monitors the access area of the roof access hatch to prevent damage or danger to persons in the travel range of the two opening flaps. The triggered sensor stops driving or prevents starting.

Controls

All control of the roof access hatch is via an associated control unit. The control unit is housed in an external casing. The control unit releases the movement or blocks it if the sensor is interrupted.

For the operation of the roof access hatch, a button without self-holding must be installed on site. The roof access hatch may only be operated by instructed persons. The positioning of the button must be such that the operator has direct visual contact with the roof access hatch, thus ensuring additional personal safety.

	Note
i	To ensure authorised operation of the roof access hatch, the use of a key switch is required.

In order to be able to move the opening flaps in an emergency (e.g. to protect the inventory from damage in the event of rain or wind), the control unit has emergency control buttons (5) inside the housing (for operation, see chapter "Operation").

Operating elements for emergency operation

If there is a defect in the sensor, the control unit blocks all movements.

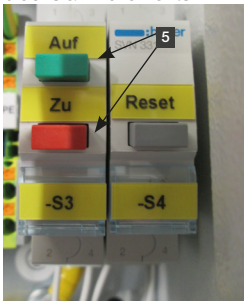



6. OPERATION

6.1 Safety

Warning	
	<p>Risk of falling!</p> <p>The roof access hatch and roof edges pose a risk of severe to fatal injury from falls.</p> <ul style="list-style-type: none"> >> Do not step onto edges which could be fallen from. >> Seal off danger zones. >> Wear personal protective equipment.

Warning	
	<p>Risk of crushing!</p> <p>Opening and closing the roof access hatch poses a risk of injury.</p> <ul style="list-style-type: none"> >> Do not loiter in the exit area when opening and closing the device. >> Do not reach into moving parts.

Warning	
	<p>Risk of injury!</p> <p>Opening and closing the roof access hatch poses the risk of injuring third parties.</p> <ul style="list-style-type: none"> >> Only instructed operators are permitted to operate the roof access hatch. >> When opening and closing, maintain eye contact with the roof access hatch to protect third parties from danger.

Warning	
	<p>Risk of injury from improper protective equipment or lack of protective equipment!</p> <p>Personal protective equipment must be worn during work to minimize the risk of health risks or personal injury.</p> <ul style="list-style-type: none"> >> The protective equipment necessary for the task at hand must be worn at all times during work. >> Follow notices on personal protective equipment posted in the work area.

	Note
i	In the event of a power failure, the system is not functional! In the event of an impending storm, close the roof access hatch in good time.

6.2 Commissioning

The following steps must be followed before commissioning:

- Check the electrical connections.
- Proper installation of the roof access hatch.
- Check the travel movement of the opening flaps for degree of freedom.
- Check that opening flaps are guided free of mechanical stresses.
- Check the function of the sensor. To do this, place an obstacle in the detection area. The drives must be stopped immediately or must not start. A restart may only take place after the obstacle has been removed from the detection range!

Safety acceptance

After completion of the above tests, a safety acceptance test must be carried out. The inspector certifies compliance with all requirements for the installation and operation of the roof access hatch. If special conditions prevail at the installation site which may cause additional hazards than those mentioned in this instruction manual, the acceptor shall assess the sufficiency of any additional protective measures taken and the safety of operation. The safety inspection may only be carried out by qualified personnel. The safety inspection protocol must be completed (see chapter 10).

The safety approval refers to the function as a roof access hatch.

Ready-for-operation handover

After the functional and safety checks, the roof access hatch can be handed over ready for operation.

These include:

- Handing over of the documents for the safety approval
- Assembly instructions and instruction manual
- Instruction of operators

6.3 Operation

Normal operation

The roof access hatch can be operated by means of the push-button installed on site.

To this end:

- Make visual contact with the roof access hatch and assess the danger to third parties.
- Make sure that no objects are placed on the flap or the frame
- Press the button function for the desired direction of travel (OPEN/CLOSED).

	Note
i	The drives of the roof access hatch run as long as the button is pressed. If the actuation ends, the drives stop immediately (dead-man).

If an obstacle enters the detection range of the sensor, the drives stop immediately or do not start.

In this case:

- Remove the obstacle and press the button again as described.

	Note
i	The profiles are thermally separated. However, under unfavourable climatic conditions (e.g. high

	Note
	<p>level of humidity indoors and low outside temperatures), condensation may form temporarily on glass and aluminium surfaces. This does not constitute a defect. (See also DIN 4108 Condensation on surfaces).</p> <p>We recommend thorough ventilation at regular intervals and adequate heating in rooms to prevent the build-up of condensation.</p>

Emergency operation

Emergency operation may only be carried out by a qualified electrician if there is a defect in the sensor and the roof access hatch must be operated to protect against damage to property.

	Danger
	<p>Risk of electric shock!</p> <p>To operate the emergency control buttons, the housing of the control unit must be opened. Live cables or components are not protected against access, there is thus a danger to life!</p> <p>>> Work on electrical equipment may only be conducted by a qualified electrician or instructed persons under the guidance and supervision of a qualified electrician in accordance with the rules of electrical engineering.</p>

	Warning
	<p>Risk of injury!</p> <p>When opening and closing the roof access hatch in emergency operation, there is an increased risk of injury to third parties as the drives are operated without monitoring by the sensor.</p> <p>>> Only use emergency operation if there is a defect in the sensor and the roof access hatch must be operated to protect against damage to property.</p> <p>>> Secure the driving area of the roof access hatch with suitable means (e.g. barriers, etc.).</p> <p>>> Operate skylight only with eye contact. If this is not possible, call in a safety person.</p>

To operate the roof access hatch in emergency mode, proceed as follows:

- Secure the travel area of the roof access hatch with suitable means (cordon off, provide a safety person, etc.)
- Open the housing of the control unit.

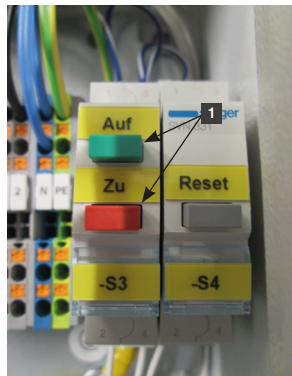

- Move the roof access hatch to the desired position by means of the emergency control button (1) while keeping visual contact or secured by safety personnel. The emergency control buttons (1) are marked accordingly with "OPEN" and "CLOSED".

Note	
i	<p>The drives of the ventilation flap run as long as the respective emergency control button is pressed.</p> <p>If the actuation ends, the drives stop immediately (dead-man).</p>

- After the emergency operation, close the housing of the control unit and take the roof access hatch out of operation (make sure that there is no voltage by switching off the power supply).
- Have the roof access hatch repaired by qualified personnel using original spare parts.

Emergency closure

Manual opening/closing

Danger	
	<p>Risk of electric shock!</p> <p>For "Emergency manual opening/closing", the control unit must be put out of operation and de-energised. Contact with live lines or components pose a life-threatening danger!</p> <p>>> Work on electrical equipment may only be carried out by a skilled electrician or be carried out by instructed persons under the direction and supervision of a qualified electrician in accordance</p>

Danger	
	<p>with the electrotechnical regulations.</p> <p>>> Establish absence of voltage, check and secure against being switched on again.</p>

Warning	
	<p>Risk of injury!</p> <p>With "Emergency closing manual opening/closing" there is a considerable risk of injury due to the necessary assembly work.</p> <p>Only allow all tasks to be carried out by persons who are qualified to undertake such tasks.</p> <p>>> Observe all specifications as specified for transport, assembly and connection of the roof access hatch (see chapter "Transport, assembly and connection").</p>

Note	
i	<p>In case of a trapped person, use the procedure "Emergency manual opening/closing".</p>

In the event of a defect in a drive or in the event of a power failure, the roof access hatch can no longer be operated.

To avoid material damage to the inventory due to rain or wind when the roof access hatch is open, there is the option of emergency closing (manual opening/closing).

Proceed as follows:

Solo roof access hatch

- Set the control unit out of operation and de-energise it.

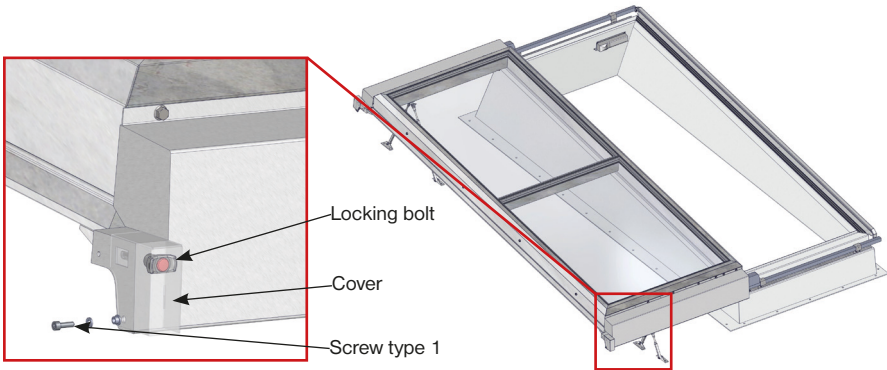

- Loosen and remove type 1 screws from the cover
- Remove cover
- Press the red button on the locking bolt to unlock and remove the bolt.
- Close the flap element manually and secure it against opening.

Duo roof access hatch

- Set the control unit out of operation and de-energise it.

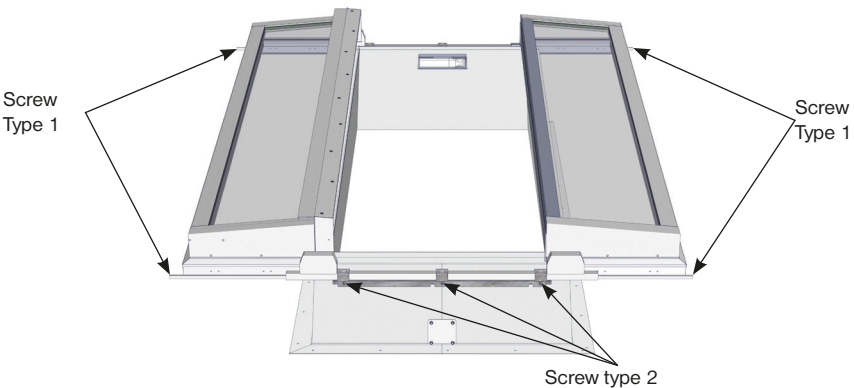

- Loosen and remove the type 1 screws at the front and rear ends of the racks.
- Loosen and remove the type 2 screws on the mounting brackets of the drives (motors).
- Remove drives.
- Close the opening flap manually and secure it against opening.

7. MAINTENANCE

7.1 Safety

Maintenance and upkeep work may only be performed by persons who:

- are authorised and capable of doing so based on their training and qualification.
- have been charged with these tasks by the operator of the roof access hatch.

Note	
i	Work on electrical equipment may only be conducted by a qualified electrician or instructed persons under the guidance and supervision of a qualified electrician in accordance with the rules of electrical engineering.

- Only perform upkeep work in accordance with the operating instructions.
- Secure the area around the roof access hatch and block it off from third parties during upkeep work.
- Disconnect the control unit and secure it to prevent it from being turned back on (hang up a warning sign in accordance with VDE).

Danger	
	<p>Risk of electric shock!</p> <p>Contact with live lines or components pose a life-threatening danger!</p> <p>>> Work on electrical equipment may only be conducted by a qualified electrician or instructed persons under the guidance and supervision of a qualified electrician in accordance with the rules of electrical engineering.</p> <p>>> Before starting work, the safety rules of electrical engineering must be followed and applied.</p>

Warning	
	<p>Risk of injury if insufficiently qualified!</p> <p>During assembly and maintenance, there is a risk of injury to the person carrying out the work by working in the danger zone. Incorrect assembly or servicing can cause hazards for subsequent operation.</p> <p>>> Installation and servicing work may only be carried out by qualified personnel.</p>

Warning	
	<p>Risk of injury!</p> <p>Opening and closing the roof access hatch poses the risk of injuring third parties.</p> <p>>> Only instructed operators are permitted to operate the roof access hatch.</p> <p>>> When opening and closing, maintain eye contact with the roof access hatch to protect third parties from danger.</p>

Warning	
	<p>Risk of falling!</p> <p>The roof access hatch and roof edges pose a risk of severe to fatal injury from falls.</p> <p>>> Do not step onto edges which could be fallen from.</p> <p>>> Seal off danger zones</p> <p>>> Wear personal protective equipment</p>

Warning	
	<p>Risk of injury from improper protective equipment or lack of protective equipment!</p> <p>Personal protective equipment must be worn during work to minimize the risk of health risks or personal injury.</p> <p>>> The protective equipment necessary for the task at hand must be worn at all times during work.</p> <p>>> Follow notices on personal protective equipment posted in the work area.</p>

Warning	
	<p>Risk of crushing!</p> <p>Opening and closing the roof access hatch poses a risk of injury.</p> <p>>> Do not loiter in the exit area when opening and closing the device.</p> <p>>> Do not reach into moving parts.</p> <p>>> Secure the area around the roof access hatch and block it off from third parties during upkeep work.</p> <p>>> Disconnect the control unit and secure it to prevent it from being turned back on (hang up a warning sign in accordance with VDE).</p>

	<p>Harness for fall protection</p>
---	------------------------------------

After any upkeep work:

- inspect safety systems.
- check to make sure the roof access hatch is functioning flawlessly.

7.2 Maintenance

Regular maintenance work is necessary in order to ensure flawless functioning of the roof access hatch and its components.

Carry out maintenance according to the maintenance schedule. If damage to the roof access hatch, components or restrictions in function are detected in the course of maintenance:

- Disable the roof access hatch.
- Commence repair work.

Attention	
	<p>Property damage!</p> <p>If any defects or impairments in function are detected, continued operation may seriously damage the roof access hatch.</p> <p>>> In the case of defects or impairments in function, do not use the roof access hatch and remove it from operation.</p> <p>>> Commence repair work immediately.</p>

Servicing plan

Interval *	Maintenance work
Min. 1x per year	Visual inspection of the roof access hatch and all components
	General functional test
	Function test of the safety device (sensor)
	Check emergency operation/ emergency control button for function (chapter: Operation)
	Check the ease of movement of the linear guides of the opening flaps and lubricate if necessary. Use only acid-free grease for lubrication.
	Lightly oil the moving parts regularly so as not to impair their functionality. Use only acid-free oil.
	The surrounding lip seal must be rubbed with talcum powder at regular intervals in order to keep the rubber supple and prevent it freezing in winter.

* Specified maintenance intervals are a recommendation!

The interval times depend on the prevailing environmental influences (e.g. humidity, temperature).

	Note
i	<p>The profiles are thermally separated. However, during unfavourable climate conditions (e.g. high level of humidity indoors and low outside temperatures), condensation may form temporarily on glass and aluminium surfaces. This does not constitute a defect. (See also DIN 4108 Condensation on surfaces).</p> <p>We recommend thorough ventilation at regular intervals and adequate heating in rooms to prevent the build-up of condensation.</p>

7.3 Repairs

	Warning
	<p>Risk of injury!</p> <p>Incorrect or faulty replacement parts can cause damage, malfunctions or total machine failure, and jeopardize safety.</p> <p>>> Only use original replacement parts from the manufacturer.</p>

Repairs to the roof access hatch may only be conducted by authorised specialist companies.

	Note
i	<p>The Customer Service department of LAMILUX Heinrich Strunz GmbH will be available to assist you with any questions you may have on repairs.</p>

7.4 Cleaning

The roof access hatch must be cleaned regularly (according to the degree of soiling).

	Attention
	<p>Property damage!</p> <p>Improper cleaning and impermissible cleaning agents may damage the roof access hatch.</p> <p>>> Chemical cleaner agents and solvents may not be used under any circumstances.</p> <p>>> Follow cleaning instructions.</p>

- Glass surfaces can be cleaned with commercially available washing-up liquids and window cleaners.
- Clean the painted surfaces exclusively with mild cleaning agents and using a soft sponge with sufficient water.

8. TROUBLESHOOTING

8.1 Safety

Danger	
	<p>Risk of electric shock! Contact with live lines or components pose a life-threatening danger!</p> <p>>> Work on electrical equipment may only be conducted by a qualified electrician or instructed persons under the guidance and supervision of a qualified electrician in accordance with the rules of electrical engineering.</p> <p>>> Before starting work, the safety rules of electrical engineering must be followed and applied.</p>

Warning	
	<p>Risk of crushing! Opening and closing the roof access hatch poses a risk of injury.</p> <p>>> Do not stand in the exit area when opening and closing the device</p> <p>>> Do not reach into moving parts.</p>

Warning	
	<p>Risk of injury if insufficiently qualified! When working on the roof access hatch, there is a risk of injury to the person carrying out the work by working in the danger zone. Incorrect work can cause hazards for subsequent operation.</p> <p>>> Work on the roof access hatch may only be carried out by qualified personnel.</p>

Warning	
	<p>Risk of falling! The roof access hatch and roof edges pose a risk of severe to fatal injury from falls.</p> <p>>> Do not step onto edges which could be fallen from.</p> <p>>> Seal off danger zones</p> <p>>> Wear personal protective equipment</p>

Warning	
	<p>Risk of injury from improper protective equipment or lack of protective equipment!</p> <p>Personal protective equipment must be worn during work to minimize the risk of health risks or personal injury.</p> <p>>> The protective equipment necessary for the task at hand must be worn at all times during work.</p> <p>>> Follow notices on personal protective equipment posted in the work area.</p>

If the listed points do not eliminate the fault, then:

- Lock the roof access hatch for manual operation
- Initiate repair

8.2 Malfunction and troubleshooting

In the event of a malfunction, the table below should help to determine the cause of the malfunction and to initiate a remedy.

Error	Possible cause	Troubleshooting
Roof access hatch does not move	Power supply interrupted	Check power supply and restore if necessary
	Obstacle in the detection range of the sensor	Remove obstacle and operate roof access hatch again
	Sensor defective	If necessary, close the roof access hatch as described in the chapter "Emergency operation". Take the roof access hatch out of service and initiate repair.

9. DISASSEMBLY AND DISPOSAL

9.1 Safety

Danger	
	<p>Risk of electric shock! Contact with live lines or components pose a life-threatening danger!</p> <p>>> Work on electrical equipment may only be conducted by a qualified electrician or instructed persons under the guidance and supervision of a qualified electrician in accordance with the rules of electrical engineering.</p> <p>>> Before starting work, the safety rules of electrical engineering must be followed and applied.</p>

Warning	
	<p>Risk of crushing! Opening and closing the roof access hatch poses a risk of injury.</p> <p>>> Do not stand in the exit area when opening and closing the device</p> <p>>> Do not reach into moving parts.</p>

Warning	
	<p>Risk of injury if insufficiently qualified! During assembly and maintenance, there is a risk of injury to the person carrying out the work by working in the danger zone. Incorrect assembly or servicing can cause hazards for subsequent operation.</p> <p>>> Installation and servicing work may only be carried out by qualified personnel.</p>

Warning	
	<p>Risk of falling! The roof access hatch and roof edges pose a risk of severe to fatal injury from falls.</p> <p>>> Do not step onto edges which could be fallen from.</p> <p>>> Seal off danger zones</p> <p>>> Wear personal protective equipment</p>

Warning	
	<p>Risk of injury from improper protective equipment or lack of protective equipment!</p> <p>Personal protective equipment must be worn during work to minimize the risk of health risks or personal injury.</p> <p>>> The protective equipment necessary for the task at hand must be worn at all times during work.</p> <p>>> Follow notices on personal protective equipment posted in the work area.</p>

Attention	
	<p>Improper disposal may harm the environment!</p> <p>Improper disposal may harm the environment.</p> <p>>> Electronic waste, electronic components, lubricants and other auxiliary substances are subject to special waste treatment and may only be disposed of by approved specialized companies!</p>

Note	
	<p>Your local municipal authority or specialist disposal companies will provide you with information on environmentally friendly disposal</p>

9.2 Disassembly

To disassemble the roof access hatch:

- Establish freedom from tension
- Disconnect electrical connections
- Dismantle roof access hatch
- Remove roof access hatch

9.3 Disposal

If no return or disposal agreement has been made, take the disassembled components to be recycled:

- scrap metals
- take plastic elements to recycling facility
- Sort remaining components according to material quality and dispose of them.

10. PROTOCOL OF THE SECURITY CHECK

Protocol of the safety inspection for the LAMILUX Flat Roof Access Hatch Comfort Solo and Duo

The LAMILUX Flat Roof Access Hatch Comfort Solo and Duo may only be released for use after passing a safety inspection, for which the following requirements must be met:

- Performance of all tests according to section "Results of tests performed" by qualified personnel;
- Answer "YES" to all the queries in the section "Results of the tests carried out";
- The completed and signed form on hand.

Before this safety check, the use must be effectively prevented. The inspection must be documented in this form and handed over to the operator as part of the system documentation. The safety check refers exclusively to the roof access hatch function and is to be carried out in addition to other prescribed checks. A competent person is a person who is suitable to carry out the inspection tasks due to their qualification, experience and professional activity.

Operator of the system	Name:	
	Address:	
	Phone:	Email:
Inspector	Name:	
	Address:	
	Phone:	Email:
System information	Address:	
	exact location	
	LAMILUX order number:	

Results of the inspection carried out		mark with a cross where applicable:	
		YES	NO
Control element	There is only ONE key switch, which is installed on the level of the staircase within sight of the roof access hatch.		
	The key switch is designed without a self-stop.		
	The sensor is functional.		
Safety superstructures	The installation is without automatic actuation (Smart Home controls, wind/rain sensor etc. are NOT permitted!).		
	The stairs and the step onto the roof are properly executed.		
	The safety distances on the roof are designed according to DIN EN 349.		
Roof access hatch	The roof access hatch is the only access to the roof.		
	There is a fall-proof railing around the roof access hatch.		

Declaration of the inspector

The security check was carried out in full and all questions in the table listed in the section "Results of the checks carried out" were answered truthfully with "YES". Beyond this, I am not aware of any other circumstances that could now or in the future cause a deviation from the intended use described in the documentation (see instruction manual)

or otherwise impair the operational safety of the roof access hatch.

	Location, date:
	Signature:

11. DECLARATIONS OF CONFORMITY

Flat Roof Access Hatch Comfort Solo

Deutsch / English

LAMILUX Heinrich Strunz GmbH
Zehstraße 2
D-95111 Rehau
GERMANY



Konformitätserklärung / Declaration of Conformity

Hiermit erklären wir, dass das nachstehend bezeichneten Produkte in seiner Konzeption und Bauart sowie in der von uns in Verkehr gebrachten Ausführung den grundlegenden Sicherheits- und Gesundheitsanforderungen der unten aufgeführten Verordnungen und Richtlinien entsprechen. Bei einer mit uns nicht abgestimmten Änderung des Produktes erlischt dies. Die alleinige Verantwortung für die Ausstellung dieser Konformitätserklärung trägt der Hersteller.

Hereby we declare that the products described below are in its conception and Design as well as in the execution we put on the market the basic Safety and health requirements of the regulations and directives listed below. In case of a change of the product not agreed with us, this loses. The sole responsibility for the issuance of this Declaration of Conformity lies with the manufacturer.

PRODUKTE / PRODUCTS

Produktart / product type : Dachausstieg / Roof Exit
Produktbaureihe / product series : LAMILUX Flachdach Ausstieg Komfort Solo / LAMILUX Flat Roof Exit Comfort Solo
Datum / date : 25.10.2019

VERORDNUNGEN UND RICHTLINIEN / REGULATIONS AND DIRECTIVES:

Maschinenrichtlinie 2006/42/EU – Machinery Directive 2006/42/EU

Niederspannungsrichtlinie 2014/35/EU - Low Voltage Directive 2014/35/EU

Richtlinie über elektromagnetische Verträglichkeit 2014/30/EU - Directive relating to Electro-Magnetic Compatibility 2014/30/EU

HARMONISIERTE NORMEN / HARMONIZED STANDARDS:

- DIN EN 12978: **Türen und Tore - Schutzeinrichtungen für kraftbetätigte Türen und Tore - Anforderungen und Prüfverfahren** - Industrial, commercial and garage doors and gates - Safety devices for power operated doors and gates - Requirements and test methods
- DIN EN 60335-1: **Sicherheit elektrischer Geräte für den Hausgebrauch und ähnliche Zwecke - Teil 1: Allgemeine Anforderungen** - Household and similar electrical appliances - Safety - Part 1: General requirements
- DIN EN 60335-2-103: **Sicherheit elektrischer Geräte für den Hausgebrauch und ähnliche Zwecke - Teil 2-103: Besondere Anforderungen für Antriebe für Tore, Türen und Fenster** - Household and similar electrical appliances - Safety - Part 2-103: Particular requirements for drives for gates, doors and windows
- DIN EN ISO 14120: **Sicherheit von Maschinen - Trennende Schutzeinrichtungen - Allgemeine Anforderungen an Gestaltung und Bau von feststehenden und beweglichen trennenden Schutzeinrichtungen** - Safety of machinery - Guards - General requirements for the design and construction of fixed and movable guards
- DIN EN ISO 12100: **Sicherheit von Maschinen - Allgemeine Gestaltungsgrundsätze - Risikobeurteilung und Risikominderung** - Safety of machinery - General principles for design - Risk assessment and risk reduction
- DIN EN ISO 13849-1: **Sicherheit von Maschinen - Sicherheitsbezogene Teile von Steuerungen - Teil 1: Allgemeine Gestaltungsgrundsätze** - Safety of machinery - Safety-related parts of control systems - Part 1: General principles for design
- DIN EN ISO 13849-2: **Sicherheit von Maschinen - Sicherheitsbezogene Teile von Steuerungen - Teil 2: Validierung** - Safety of machinery - Safety-related parts of control systems - Part 2: Validation
- DIN EN ISO 13850: **Sicherheit von Maschinen - Not-Halt-Funktion - Gestaltungsgrundsätze** - Safety of machinery - Emergency stop function - Principles for design

LAMILUX Heinrich Strunz GmbH
Zehstraße 2
D-85111 Rehau
GERMANY



- DIN EN ISO 13855: **Sicherheit von Maschinen - Anordnung von Schutzeinrichtungen im Hinblick auf Annäherungsgeschwindigkeiten von Körperteilen** - Safety of machinery - Positioning of safeguards with respect to the approach speeds of parts of the human body
- DIN EN ISO 13857: **Sicherheit von Maschinen - Sicherheitsabstände gegen das Erreichen von Gefährdungsbereichen mit den oberen und unteren Gliedmaßen** - Safety of machinery - Safety distances to prevent hazard zones being reached by upper and lower limbs
- DIN EN 60204-1: **Sicherheit von Maschinen - Elektrische Ausrüstung von Maschinen - Teil 1: Allgemeine Anforderungen** - Safety of machinery - Electrical equipment of machines - Part 1: General requirements
- ProdSG: **Produktsicherheitsgesetz** - Product Safety Act
- DIN EN 61439-2: **Niederspannungs-Schaltgerätekombinationen - Teil 2: Energie-Schaltgerätekombinationen** - Low-voltage switchgear and controlgear assemblies - Part 2: Power switchgear and controlgear assemblies
- DIN EN 61439-3: **Niederspannungs-Schaltgerätekombinationen - Teil 3: Installationsverteiler für die Bedienung durch Laien (DBO)** - Low-voltage switchgear and controlgear assemblies - Part 3: Distribution boards intended to be operated by ordinary persons (DBO)

SONSTIGE TECHNISCHE NORMEN UND SPEZIFIKATIONEN / FURTHER TECHNICAL STANDARDS AND SPECIFICATIONS:

Montageanweisung / Installation instructions

Sicherheitshinweise / safety instructions

Rehau, 25.10.2019

Hr. Dipl.-Ing. Joachim Hessemer
Technischer Leiter / technical director

Flat Roof Access Hatch Comfort Duo

Deutsch / English

LAMILUX Heinrich Strunz GmbH
Zehstraße 2
D-95111 Rehau
GERMANY



Konformitätserklärung / Declaration of Conformity

Hiermit erklären wir, dass das nachstehend bezeichneten Produkte in seiner Konzeption und Bauart sowie in der von uns in Verkehr gebrachten Ausführung den grundlegenden Sicherheits- und Gesundheitsanforderungen der unten aufgeführten Verordnungen und Richtlinien entsprechen. Bei einer mit uns nicht abgestimmten Änderung des Produktes erlischt dies. Die alleinige Verantwortung für die Ausstellung dieser Konformitätserklärung trägt der Hersteller.

Hereby we declare that the products described below are in its conception and Design as well as in the execution we put on the market the basic Safety and health requirements of the regulations and directives listed below. In case of a change of the product not agreed with us, this loses. The sole responsibility for the issuance of this Declaration of Conformity lies with the manufacturer.

PRODUKTE / PRODUCTS

Produktart / product type :	Dachausstieg / Roof Exit
Produktbaureihe / product series :	LAMILUX Flachdach Ausstieg Komfort Duo / LAMILUX Flat Roof Exit Comfort Duo
Datum / date :	25.10.2019

VERORDNUNGEN UND RICHTLINIEN / REGULATIONS AND DIRECTIVES:

Maschinenrichtlinie 2006/42/EU - Machinery Directive 2006/42/EU

Niederspannungsrichtlinie 2014/35/EU - Low Voltage Directive 2014/35/EU

Richtlinie über elektromagnetische Verträglichkeit 2014/30/EU - Directive relating to Electro-Magnetic Compatibility 2014/30/EU

HARMONISIERTE NORMEN / HARMONIZED STANDARDS:

- DIN EN 12978: **Türen und Tore** - Schutzvorrichtungen für kraftbetriebene Türen und Tore - Anforderungen und Prüfverfahren Industrial, commercial and garage doors and gates - Safety devices for power operated doors and gates - Requirements and test methods
- DIN EN 60335-1: **Sicherheit elektrischer Geräte für den Hausgebrauch und ähnliche Zwecke - Teil 1: Allgemeine Anforderungen** - Household and similar electrical appliances - Safety - Part 1: General requirements
- DIN EN 60335-2-103: **Sicherheit elektrischer Geräte für den Hausgebrauch und ähnliche Zwecke - Teil 2-103: Besondere Anforderungen für Antriebe für Tore, Türen und Fenster** - Household and similar electrical appliances - Safety - Part 2-103: Particular requirements for drives for gates, doors and windows
- DIN EN ISO 14120: **Sicherheit von Maschinen - Trennende Schutzvorrichtungen - Allgemeine Anforderungen an Gestaltung und Bau von feststehenden und beweglichen trennenden Schutzvorrichtungen** - Safety of machinery - Guards - General requirements for the design and construction of fixed and movable guards
- DIN EN ISO 12100: **Sicherheit von Maschinen - Allgemeine Gestaltungsgrundsätze - Risikobeurteilung und Risikominderung** - Safety of machinery - General principles for design - Risk assessment and risk reduction
- DIN EN ISO 13849-1: **Sicherheit von Maschinen - Sicherheitsbezogene Teile von Steuerungen - Teil 1: Allgemeine Gestaltungsgrundsätze** - Safety of machinery - Safety-related parts of control systems - Part 1: General principles for design
- DIN EN ISO 13849-2: **Sicherheit von Maschinen - Sicherheitsbezogene Teile von Steuerungen - Teil 2: Validierung** - Safety of machinery - Safety-related parts of control systems - Part 2: Validation
- DIN EN ISO 13850: **Sicherheit von Maschinen - Not-Halt-Funktion - Gestaltungsgrundsätze** - Safety of machinery - Emergency stop function - Principles for design

LAMILUX Heinrich Strunz GmbH
Zehstraße 2
D-95111 Rehau
GERMANY



- DIN EN ISO 13855: **Sicherheit von Maschinen - Anordnung von Schutzeinrichtungen im Hinblick auf Annäherungsgeschwindigkeiten von Körperteilen** - *Safety of machinery - Positioning of safeguards with respect to the approach speeds of parts of the human body*
- DIN EN ISO 13857: **Sicherheit von Maschinen - Sicherheitsabstände gegen das Erreichen von Gefährdungsbereichen mit den oberen und unteren Gliedmaßen** - *Safety of machinery - Safety distances to prevent hazard zones being reached by upper and lower limbs*
- DIN EN 60204-1: **Sicherheit von Maschinen - Elektrische Ausrüstung von Maschinen - Teil 1: Allgemeine Anforderungen** - *Safety of machinery - Electrical equipment of machines - Part 1: General requirements*
- ProdSG: **Produktsicherheitsgesetz** - *Product Safety Act*
- DIN EN 61439-2: **Niederspannungs-Schaltgerätekombinationen - Teil 2: Energie-Schaltgerätekombinationen** - *Low-voltage switchgear and controlgear assemblies - Part 2: Power switchgear and controlgear assemblies*
- DIN EN 61439-3: **Niederspannungs-Schaltgerätekombinationen - Teil 3: Installationsverteiler für die Bedienung durch Laien (DBO)** - *Low-voltage switchgear and controlgear assemblies - Part 3: Distribution boards intended to be operated by ordinary persons (DBO)*

SONSTIGE TECHNISCHE NORMEN UND SPEZIFIKATIONEN / FURTHER TECHNICAL STANDARDS AND SPECIFICATIONS:

Montageanweisung / *Installation instructions*

Sicherheitshinweise / *safety instructions*

Rehau, 25.10.2019

/ppa. Dipl.-Ing. Joachim Häselner
Technischer Leiter / *technical director*



Scan here to learn more
about LAMILUX daylight systems!



ROOFLIGHT F100



GLASS SKYLIGHT F100



GLASS SKYLIGHT FE



GLASS ROOF



RENOVATION



MIROTEC STEEL CONSTRUCTION



CONTINUOUS ROOFLIGHT B



CONTINUOUS ROOFLIGHT S



CONTINUOUS ROOFLIGHT
W|R



SMOKE AND
HEAT EHAUST VENTILATION
SYSTEMS



BUILDING CONTROL SYS-
TEMS



RODA LICHT-
UND LUFTECHNIK

The technical data printed in this brochure was accurate when this brochure went to press and is subject to change without notice. Our technical specifications are based on calculations and supplier information or have been determined during testing by independent testing authorities within the scope of applicable standards.

Thermal transmittance coefficients for our composite glazing were calculated using the finite element method with reference values as per DIN EN 673 for insulated glass. Based on empirical values and specific characteristics of the plastics, a temperature vector of 15 K was defined as the vector between the outer surfaces of the material. Functional values refer to test specimens and the dimensions used in testing only. We cannot provide any further guarantees of technical values. This particularly applies to changes in installation locations, or if dimensions are re-measured on site.



LAMILUX Heinrich Strunz GmbH

Zehstrasse 2 · Postfach 1540 · 95111 Rehau · Tel.: +49 (0) 92 83 / 5 95-0 · Fax +49 (0) 92 83 / 5 95-29 0

E-mail: information@lamilux.de · www.lamilux.de

